

DIN 934

Hexagon nuts

Steel | bright | Cr(VI) - free | Metric Thread

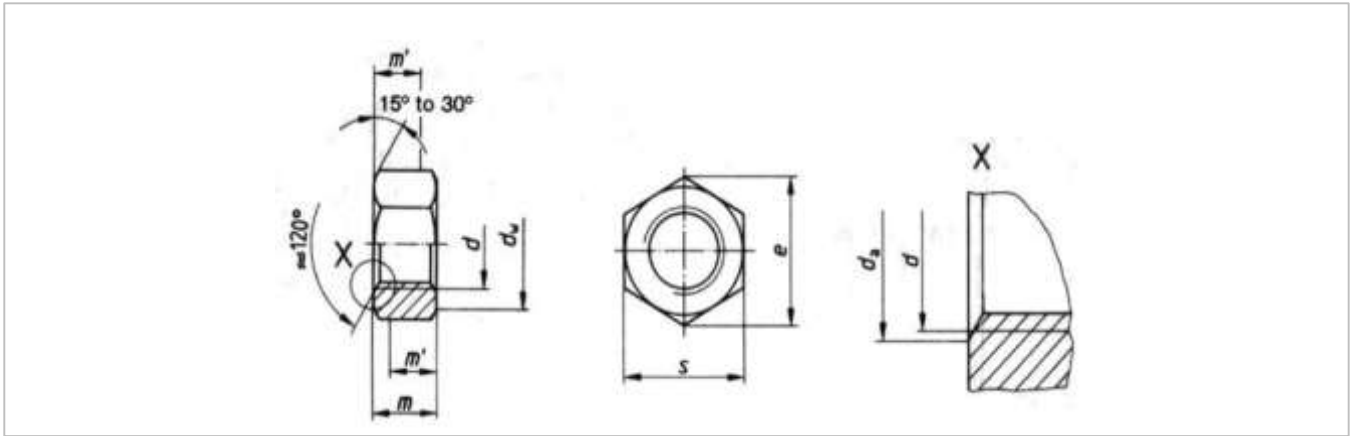

Çap (d)	d _a		d _w	e	m		m'	s	
	min.	max.			min.	max.		min.	max.
M4	4,00	4,60	5,80	7,66	2,90	3,20	2,32	6,78	7,00
M5	5,00	5,75	6,80	8,79	3,70	4,00	2,96	7,78	8,00
M6	6,00	6,75	8,80	11,05	4,70	5,00	3,76	9,78	10,00
M7	7,00	7,75	9,50	12,12	5,20	5,50	4,16	10,73	11,00
M8	8,00	8,75	11,30	14,38	6,14	6,50	4,91	12,73	13,00
M10	10,00	10,80	15,30	18,90	7,64	8,00	6,11	16,73	17,00
M12	12,00	13,00	17,20	21,10	9,64	10,00	7,71	18,67	19,00
M14	14,00	15,10	20,20	24,49	10,3	11,00	8,24	21,67	22,00
M16	16,00	17,30	22,20	26,75	12,30	13,00	9,84	23,67	24,00